



Structural Pallet Rack

The ideal system for heavy-duty loads due to its greater weight-bearing capacity

interlake
MECALUX



General Characteristics of Structural Rack

Made from highly resistant, hot rolled steel, the extra thick horizontal load beams of the Structural Rack are designed for greater weight-bearing capacity. The rack's components can be used in multiple configurations including Selective Pallet Rack, Drive-In/Drive Thru, Push-Back and more.

Structural steel components may also be integrated with roll formed components to provide a more economical alternative than an entire structural system.

Both structural load beams and structural upright frames offer heavier weight capacities than their non-structural counterparts.

Structural Frames

The structural uprights are essential to the strength and durability of a Structural Rack system. The vertical posts are connected by both horizontal and diagonal bracing.

Post Sections and Foot Plates

The orientation of the post section and its attachment to the foot plate are essential to the overall strength and usage of the Structural system.

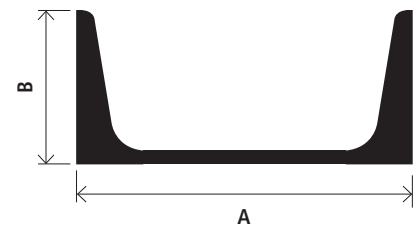
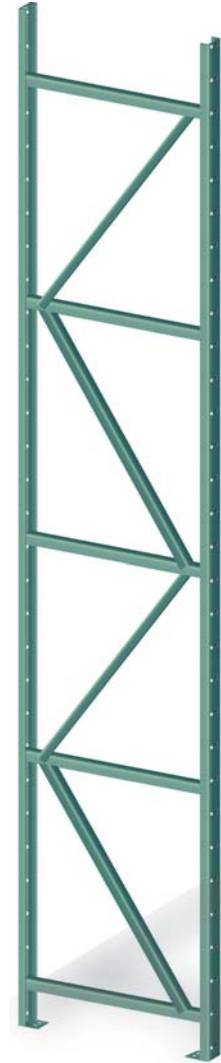

Welded Frame Capacity (lbs.)					
		335	345	435	455
Height between Levels	36"	25,400	30,600	42,100	47,900
	42"	25,400	30,600	42,100	47,900
	48"	25,400	30,600	42,100	47,900
	54"	25,400	30,600	42,100	47,900
	60"	25,400	30,600	42,100	47,900
	66"	25,400	30,600	42,100	47,900
	72"	25,400	30,600	42,100	47,900
	78"	23,900	27,500	42,100	47,900
	84"	21,100	24,200	40,900	47,000
	90"	18,500	21,200	37,900	43,400
	96"	16,400	18,600	34,900	39,800



Single Column

Single column

The standard orientation, providing additional strength and durability than non-structural posts and foot plates.



Closed Post Reinforcement

Closed post reinforcement

This post orientation is a cleaner option that offers greater load capacities and a higher resistance to torsion.

Welded Columns Dimensional Chart		
Frame	A	B
335	3"	1.37"
345	3"	1.41"
435	4"	1.58"
455		

Structural Beams

The structural load beams are an integral part of the Structural Rack system. Unbraced structural beams have a 6 percent higher load capacity than roll formed beams. Single-braced structural beams can hold 70 percent more than normal roll formed beams. Contact your Interlake Mecalux representative for more details.

C Channel Beam

The standard structural bolted beam is vertically adjustable on 2" centers to provide a durable horizontal component for this high-capacity system.

C Beams can be used with either structural or standard roll formed uprights.

Roll Formed Beam

The RF Beam offers customizable options dependent upon the frames used. Contact your Interlake Mecalux representative for details.



Structural beam with structural end plate



Roll formed beam with structural end plate

Structural Accessories



Row Spacer

These galvanized separators secure back-to-back rows by attaching to the upright columns. The uniform space created can be used with welded structural systems as a flue space between rack rows.



Frame and Aisle Protectors

Used to protect against forklift damage, these can be configured for individual uprights or for aisles. They are 16" high and come with four anchor bolts to affix them to the floor.



End Aisle Protector



Right Protector



Left Protector



Center Protector

Welded Structural Beam Capacities

Beam capacities are dependent on the presence of bolt-in crossbars and lateral brace rods.

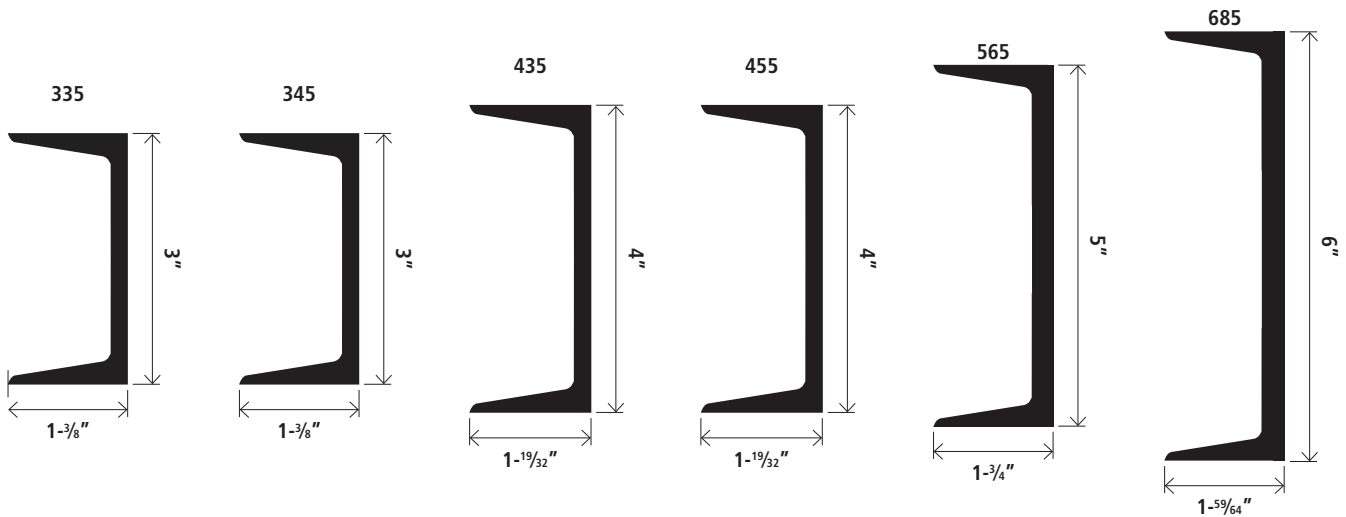

Span (in)	335		345		435		455		565		685	
	Un-braced	Single Brace	Un-braced	Single Brace	Un-braced	Single Brace	Un-braced	Single Brace	Un-braced	Single Brace	Un-braced	Single Brace
48	10,050	10,320	11,660	11,660	15,120	15,120	15,120	15,120	15,120	15,120	15,120	15,120
54	8,690	9,220	10,170	10,420	14,650	15,120	15,120	15,120	15,120	15,120	15,120	15,120
60	7,590	8,350	8,950	9,420	12,710	14,210	14,270	15,120	15,120	15,120	15,120	15,120
66	7,420	8,460	8,810	9,540	12,370	14,360	14,340	15,120	15,120	15,120	15,120	15,120
72	6,580	7,730	7,880	8,620	10,580	13,200	12,700	14,860	15,120	15,120	15,120	15,120
78	5,880	6,640	7,080	7,390	9,530	12,220	11,310	13,750	15,120	15,120	15,120	15,120
84	5,260	5,770	6,400	6,420	8,170	11,380	10,120	12,800	15,120	15,120	15,120	15,120
90	4,580	5,060	5,620	5,620	7,090	10,660	8,800	11,980	13,380	15,120	15,120	15,120
96	4,030	4,480	4,980	4,980	6,210	10,010	7,780	11,040	11,690	15,120	15,120	15,120
102	3,580	3,990	4,430	4,430	5,490	8,910	6,880	9,810	10,310	15,120	14,460	15,120
108	3,200	3,590	3,980	3,980	4,880	7,980	6,130	8,790	9,160	15,120	12,810	15,120
114	2,870	3,240	3,590	3,590	4,370	7,190	5,490	7,920	8,170	14,540	11,420	15,120
120	2,600	2,940	3,260	3,260	3,940	6,310	4,950	7,170	7,370	13,570	10,250	15,120
126	2,330	2,690	2,980	2,980	3,530	5,760	4,440	6,530	6,600	12,340	9,160	15,120
132	2,130	2,470	2,760	2,730	3,210	5,280	4,040	5,970	6,000	11,270	8,310	15,120
138	1,950	2,270	2,510	2,510	2,930	4,850	3,690	5,490	5,470	10,340	7,560	15,120
144	1,790	2,100	2,320	2,320	2,690	4,480	3,380	5,060	5,010	9,520	6,920	15,120

Note:

- Load capacities are for uniformly distributed product load + dead load per pair of beams (dead load = weight of beams).
- Beams > 90" that support decking must be tied together to prevent spreading.
- Beams 60" long and under are designed for single pallet wide applications.
- Beams longer than 60" are designed for 2-3 pallet wide applications.

- Capacities have already been reduced for impact loading.
- Capacities are valid when beams are connected to Interlake Mecalux frames.
- Capacities are based on the 2012 RMI and the 2006 AISI specifications.
- These capacities assume that all component parts are: (1) Manufactured by Interlake Mecalux. (2) In good condition. (3) Properly installed.



Structural Selective Rack

Combining specially designed structural frames with horizontal load beams, Structural Selective Rack provides the same product versatility and easy pallet access as standard roll formed selective rack, while also accommodating heavier loads.

Designing a selective system with structural material maximizes throughput and storage capacity, resulting in a unit built to accommodate years of growth.

To compare the differences between structural and roll formed frames offered by Interlake Mecalux, the bolted 314 Selective Frame has a capacity of 20,867 lbs. per bay at a span of 48". The equivalent welded 335 Structural Selective frame can hold 4,533 pounds more than its roll formed counterpart.

Components

1. Structural Frame
2. Beam
3. Horizontal strut
4. Diagonal strut
5. Foot plate

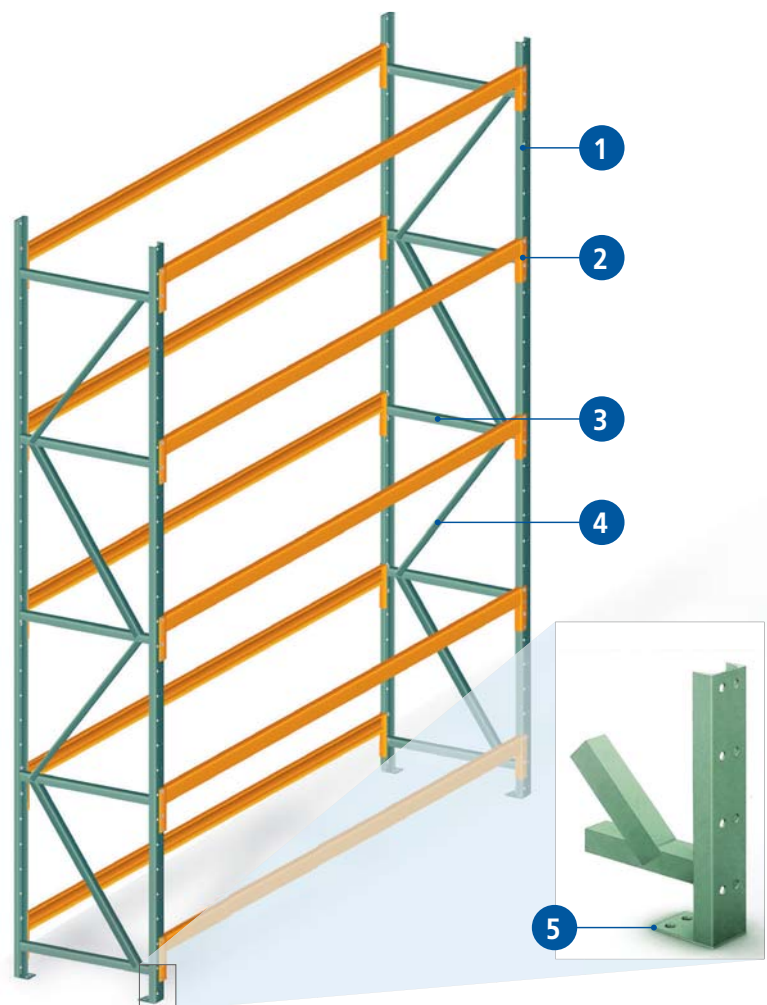



Structural Selective Accessories



Hang-On Support Bar



Bolt-In Cross Bar

Pallet Support Bars

Designed to be used between the structural beams, the pallet support bars support the bottom of the pallet load and work as a brace.



Skid Channel

Steel roll formed channel designed to evenly distribute supported load over beams.



Fork Clearance Bar

These are used when goods are stored without pallet support or other protective materials. In addition to keeping the goods separated and ventilated, they also allow enough space for forklifts to easily access and move the goods.

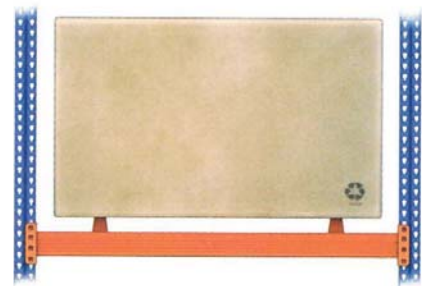



Structural Drive-In

The Structural Drive-In / Drive-Thru systems maximize the use of space within a warehouse, allowing for the storage of large pallet quantities of comparable products. Products stored in a loading lane should have the same SKU to avoid unnecessary pallet handling.

With the load raised slightly above the level on which it is to be deposited, forklifts enter the system and deposit pallets on support rails. This action is repeated at various levels. This system offers a highly dense storage option.

The depth of each lane will depend on the number of pallets per SKU, the occupied space and the length of time they will be stored.

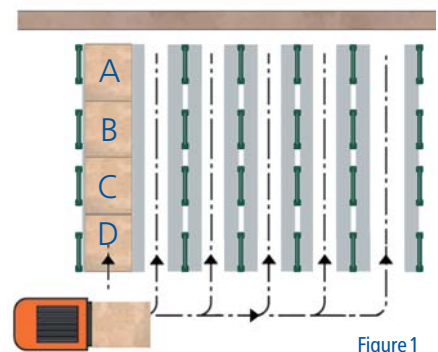

Figure 1

Rack load management

Drive-In

The racks are equipped with a single access aisle, where loading and unloading follow the first in, last out order (Figure 1).

Drive-Thru

The load is managed in this case with two accesses to the load, one on each side of the system (Figure 2).

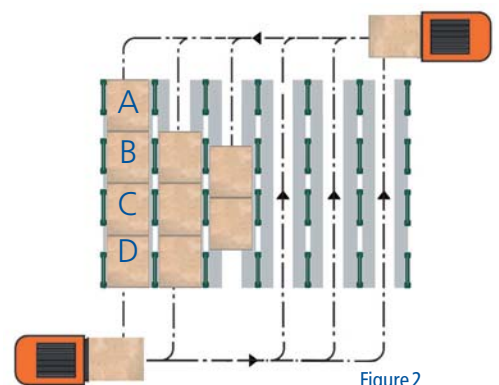
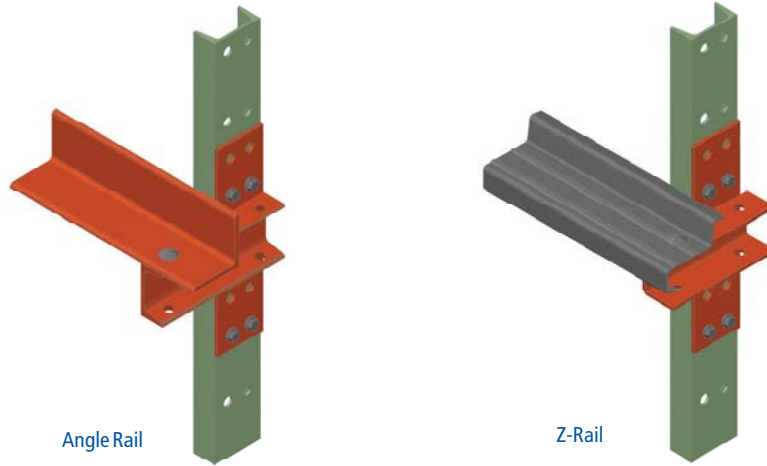

Figure 2

Structural Drive-In/Drive-Thru Arms and Rails

Bolted to the structural uprights, these arms extend the rail to the left, the right or both sides of the upright. Rails are bolted on the ends to provide a compacted space for product storage, with clearance for lift trucks to enter the system and support pallets simultaneously.



Components

- 1. Frame
- 2. Top tie beam
- 3. Arm
- 4. Foot plate
- 5. Shims
- 6. Horizontal bracing
- 7. Rigidity lane
- 8. Rail

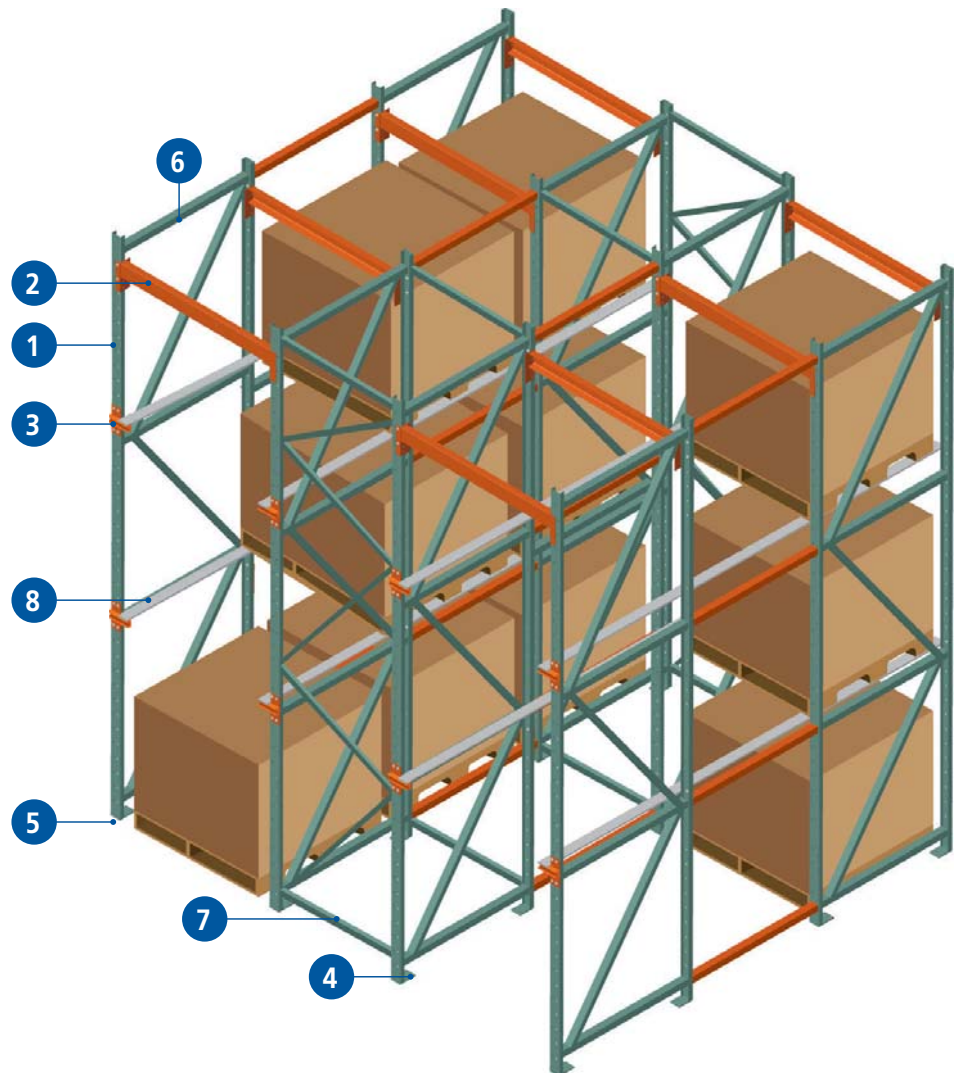



Structural Push-Back

Interlake Mecalux Structural Push-Back is an accumulative, high-density last-in / first-out (LIFO) storage system of up to five pallets deep that allows multiple-product storage conformations to ensure excellent selectivity.

The pallets are placed on a free-rolling carriage that pushes back into the system when additional pallets are loaded. Gravity moves the pallets forward to the aisle on the structural telescoping carts, eliminating the need to reach or drive into the rack.

This system minimizes space requirements and maximizes the number of picking faces.

There is no wasted space with the Structural Push-Back system. Increased selectivity and SKU qualities produce increased throughput. No matter how you modify the system, any Push-Back specification will facilitate efficient storage and the easiest product accessibility.

Conventional warehouse storage system



Push-back warehouse storage system

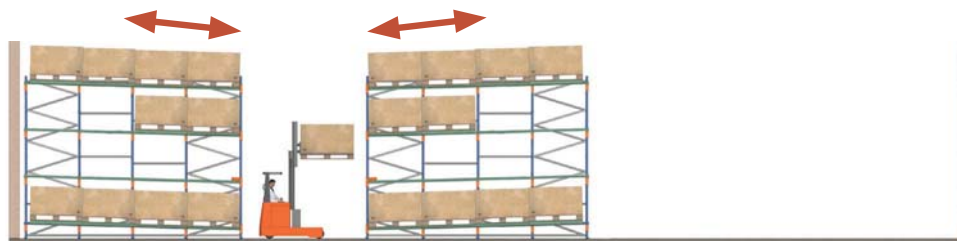

Assembly for multiple pallet depths

Assembling a two-pallet system incorporates two rails and a cart that slides above these rails. The first pallet rests on the cart, and the second rests directly on the rails.

Assembly for additional depths of three, four and five pallets requires additional rails for the two, three or four additional carts.

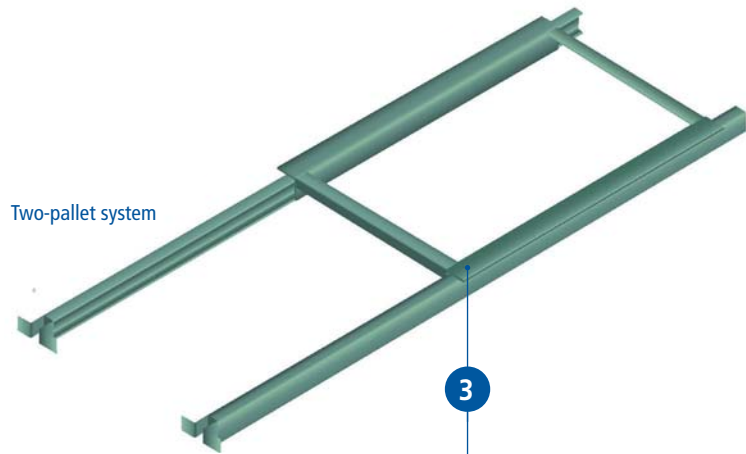

Components

- 1. Structural frame
- 2. Structural beam
- 3. P.B. cart
- 4. P.B. rail support
- 5. Structural frame bracing

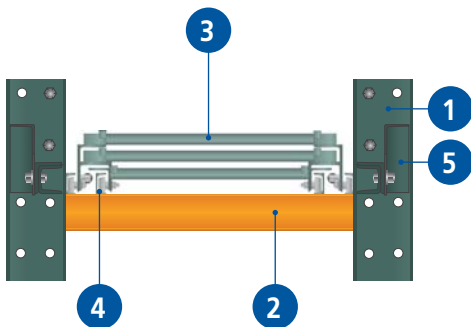
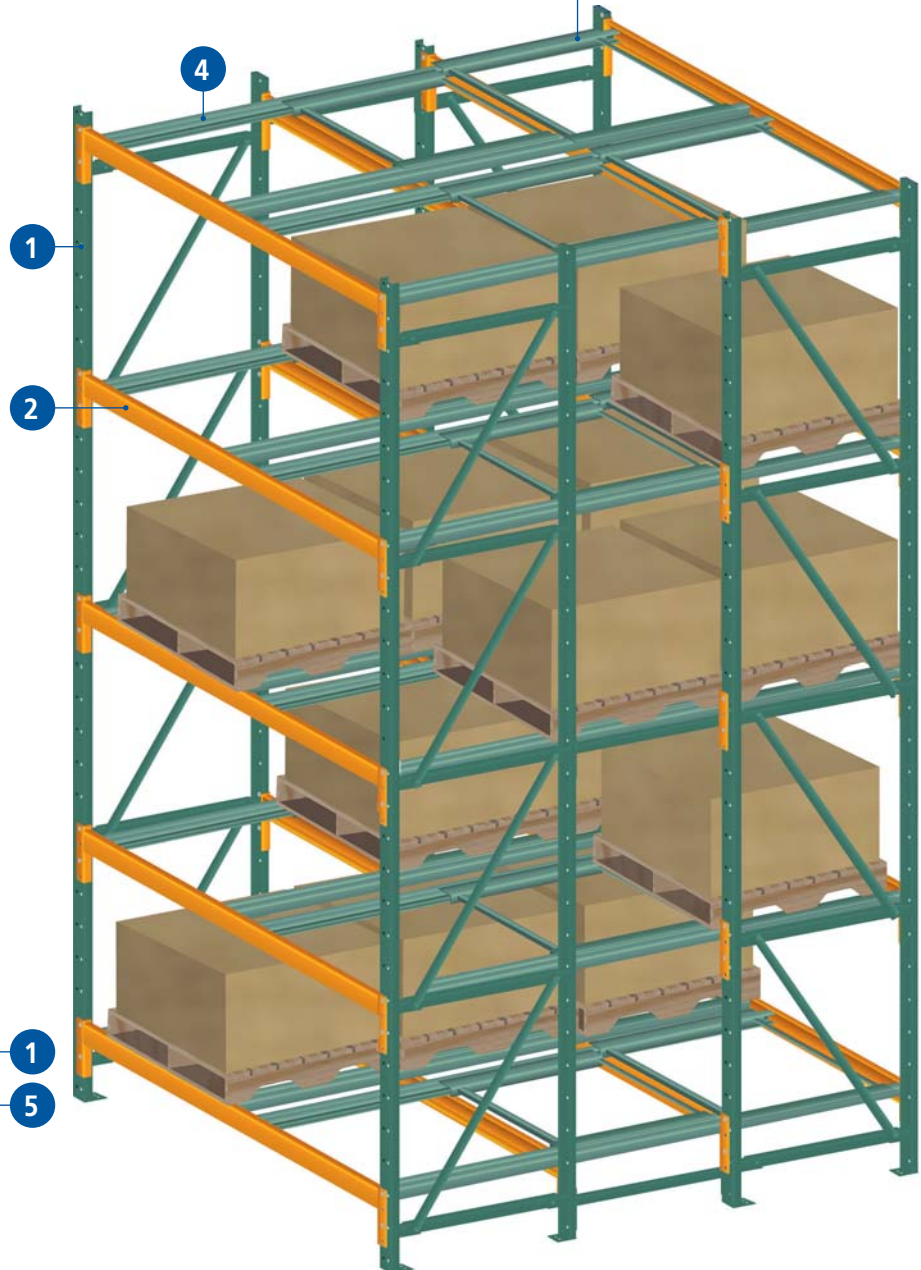



Structural Pallet Flow

Interlake Mecalux Structural Pallet Flow is a fully adaptable first-in / first-out (FIFO) storage system of up to four pallets deep that incorporates sloped lanes of roller track sections.

Pallets enter on the high end of the lanes and move gravitationally toward the other end. There, they will be picked easily since all the SKUs are available in the same unloading aisle. The loading aisle is separated, which eliminates congestion from forklifts having to share the space to carry out both tasks. SKUs are also separated by loading lane, allowing for premium stock control.

The safe and reliable Structural Pallet Flow system is ideal for intermediate warehouses between two work areas, perishable product warehouses, high turnaround shipment areas and holding warehouses.

Components

1. Structural frame
2. Beam
3. Horizontal bracing
4. Diagonal bracing
5. Foot plate
6. Roller track

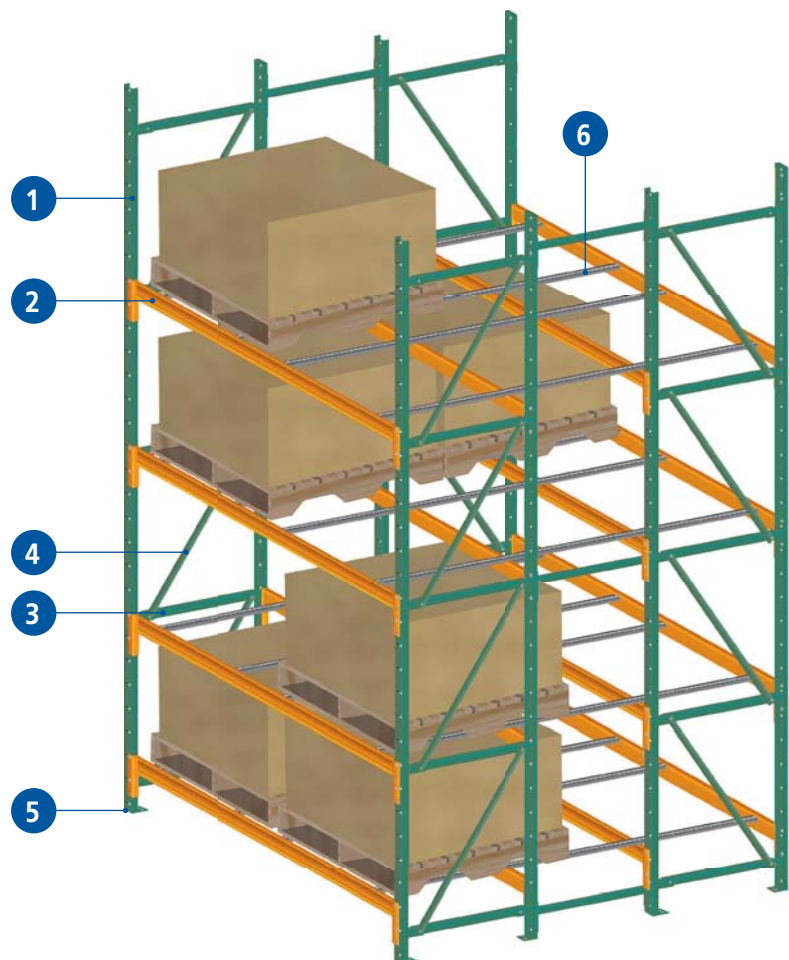



Structural Mezzanine

Mezzanines maximize warehouse spaces by doubling their surface areas. These easily installed structures can be disassembled, modified and reused to complement any facility while allowing valuable ground floor space to remain open for other storage.

Whether it is extra storage, additional offices or changing rooms, adding a mezzanine can be an economical way to meet your warehouse needs, saving you the cost of conventional building expansions.

Components

1. Structural upright
2. Main beams
3. Secondary beams
4. Floor
5. Angle bracket
6. Foot plate
7. Anchor
8. Staircase
9. Handrail with kick plate
10. Pallet gate

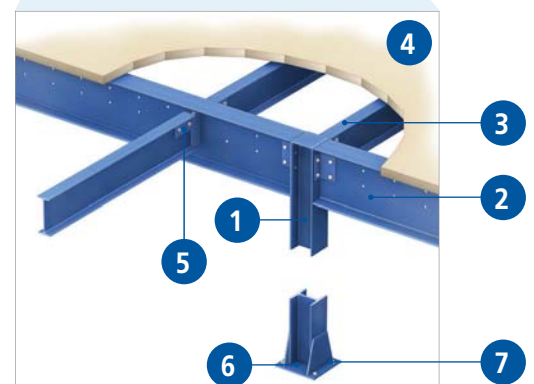
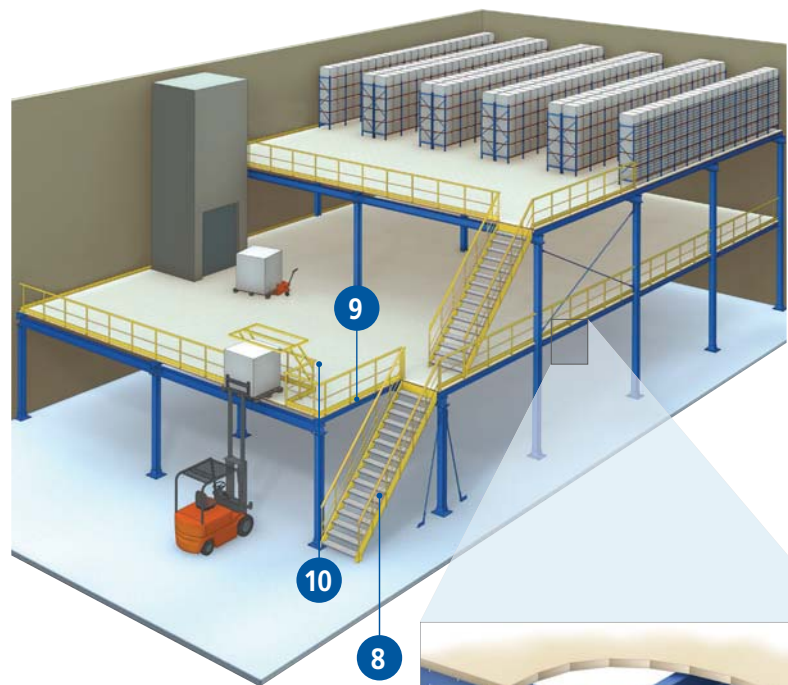



Structural Cantilever

Cantilever racking is a system designed to store long or varying length items, such as metal beams, pipes, molding, wooden boards, plastic sheets and a wide range of other materials.

The open and adjustable system consists of a series of arms attached to structural posts; these are anchored by substantial bases and x-bracing. Loads are placed on the arms.

Damaged Structural Cantilever components may be repaired just as easily as Roll Formed Cantilever.

Components

1. Structural upright
2. Arm
3. Base
4. Horizontal bracing
5. Cross bracing (x-bracing)
6. Bolted bracing tab
7. Pipe stop

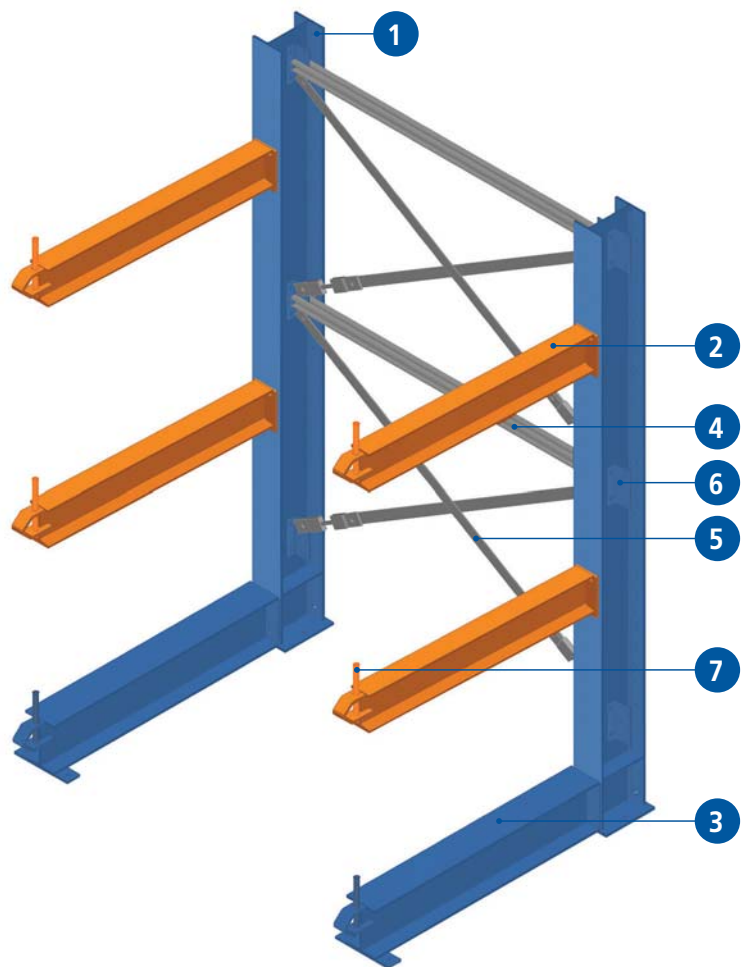



Structural Cantilever Arms

Structural arms are used with heavy loads or in situations where minimal movement of the arms is required. They are manufactured in sizes ranging from S3 x 5.7" (Figure 1) to S6 x 12.5" (Figure 2).

A plate is welded to one end for bolting onto the uprights, while a curved piece on the opposite end serves to facilitate load placement and attach the arm stops.

Once assembled, the arms slope slightly toward the column, ensuring extra safety.

Arm stops

The arm stops are metal tubes inserted in the top hole at the end of the arm preventing loose goods from falling.

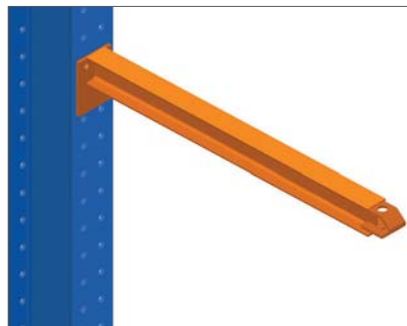
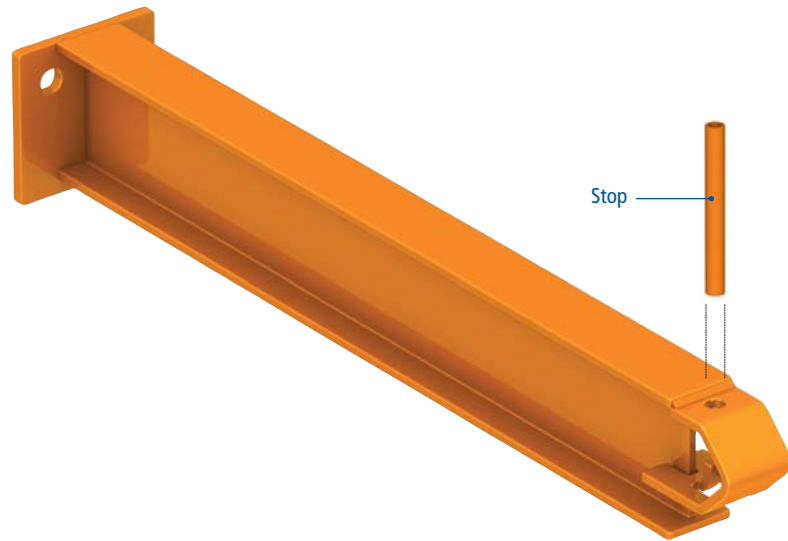

Figure 1: Arm S3 x 5.7

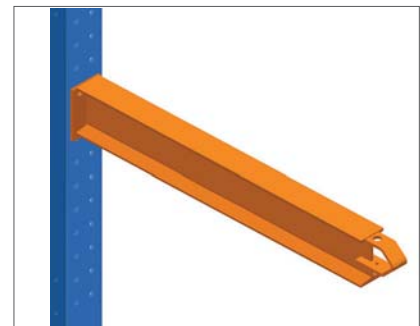

Figure 2: Arm S6 x 12.5



Tel. 1-877-632-2589 - info@interlakemecalux.com - interlakemecalux.com

SALES OFFICES

CHICAGO
1600 North 25th Ave.
Melrose Park, IL 60160

DALLAS
3333 West University Drive
BLDG 2 unit 2105,
Denton TX 76207

SAN DIEGO
8607 Ave. De La Fuente
San Diego, CA 92154

PRODUCTION PLANTS

CHICAGO
1600 North 25th Avenue
Melrose Park, IL 60160

MATAMOROS
Las Rusias 2700,
Industrial del Norte
Matamoros Tamaulipas,
C.P. 87316

PONTIAC
701 Interlake Drive
Pontiac, IL 61764

TIJUANA
Blvd. Bellas Artes, 9001
Ciudad Industrial Nueva Tijuana
Tijuana, B.C. - C.P. 22444

OFFICES WORLDWIDE

Argentina - Belgium - Brazil - Canada - Chile - Colombia - Czechia - Croatia - France - Germany - Italy - Mexico
Netherlands - Poland - Portugal - Romania - Slovakia - Slovenia - Spain - Turkey - United Kingdom - Uruguay - USA



The contents in this document refer exclusively to Mecalux products and are for informational and promotional purposes only. The information contained herein does not form the basis for warranty or guarantee. Mecalux reserves the right to modify without prior notice the data, figures, products and finishes in the catalog.